

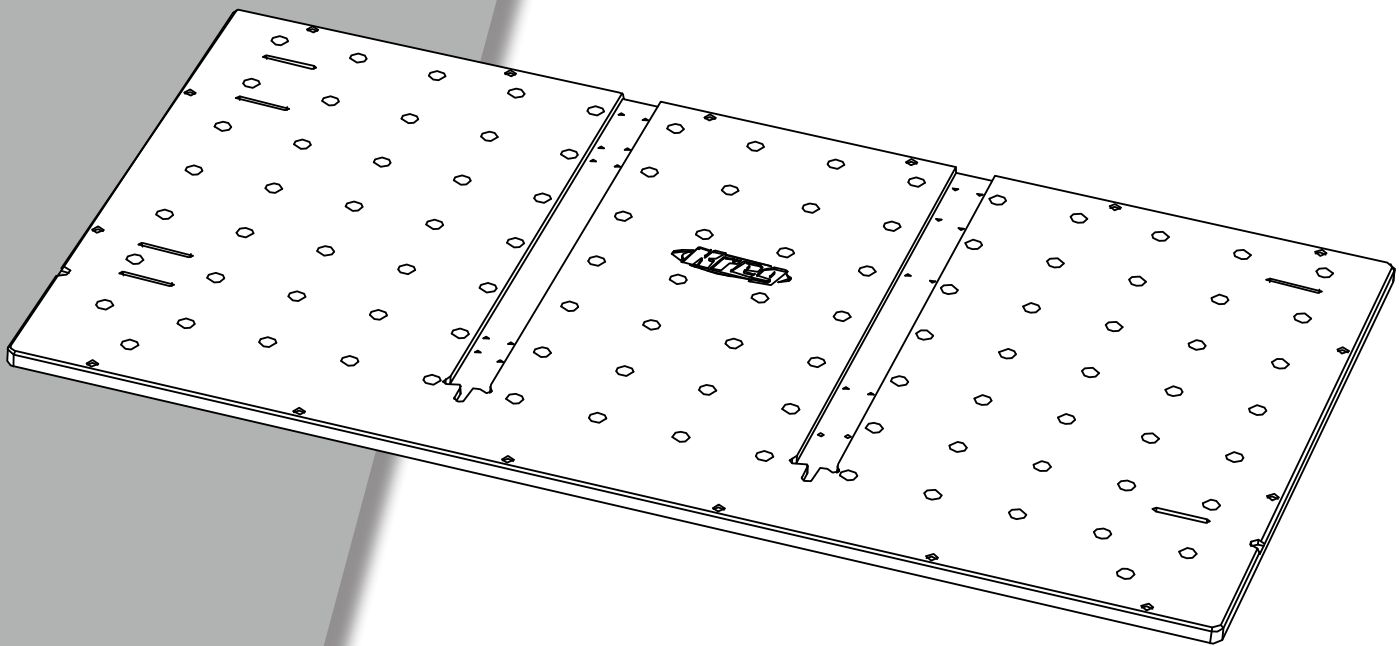

**ADAPTIVE
CUTTING
SYSTEM**

Owner's Manual

Guide d'utilisation / Manual del propietario



PROJECT TABLE REPLACEMENT TOP IS COVERED IN THIS MANUAL

PARTS

BEFORE YOU BEGIN

Check the contents of the carton to ensure you have all parts in the quantities listed. Should any part be missing, contact Kreg Customer Service. Refer to your original Adaptive Cutting System Project Table owner's manual for part identification and reassembly instructions.

WARNING: This product can expose you to chemicals including Formaldehyde, which is known to the State of California to cause cancer. For more information go to www.P65Warnings.ca.gov.

CONTENTS: ACS745

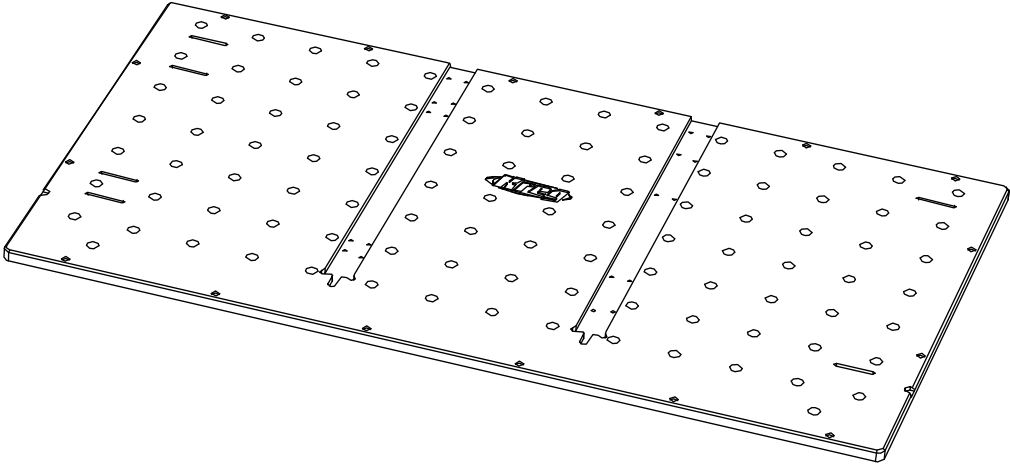
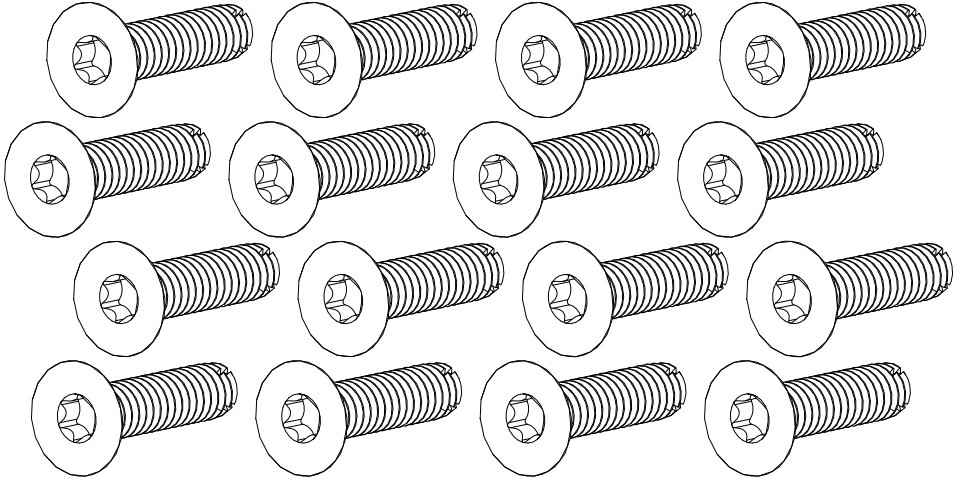
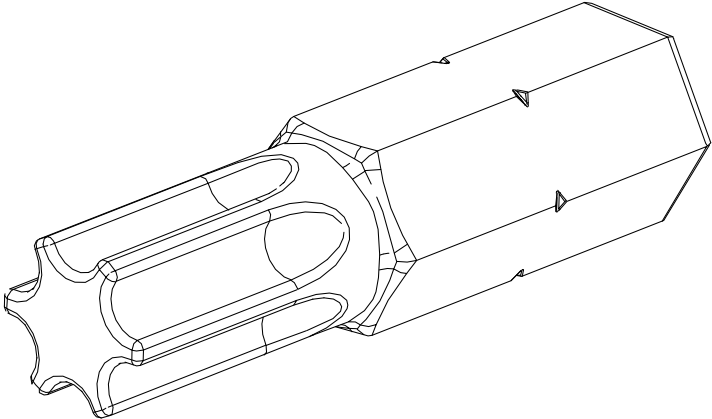
ITEM	DESCRIPTION	QUANTITY
	Project Table Top	1
	Table-Top Screws	16
	Star-Drive Bit	1

SETUP

Remove the old Project Table Top

(1) Remove the guide track, hinges, hinge-mounting plates, and all corresponding hardware. Retain all components for reassembly.

(2) Place the Project Table upside down on a flat surface that will support the table tracks when the nuts securing them to the table top are removed.

⚠ ATTENTION: Two people are required to lift the Project Table.

(3) Remove all nuts, bar brackets, and U-bolts fastening leg assemblies 1 and 2; the wheel assembly; and the four nuts attaching the table tracks to the Project Table top. **Retain all nuts, bar brackets, and U-bolts for reassembly.**

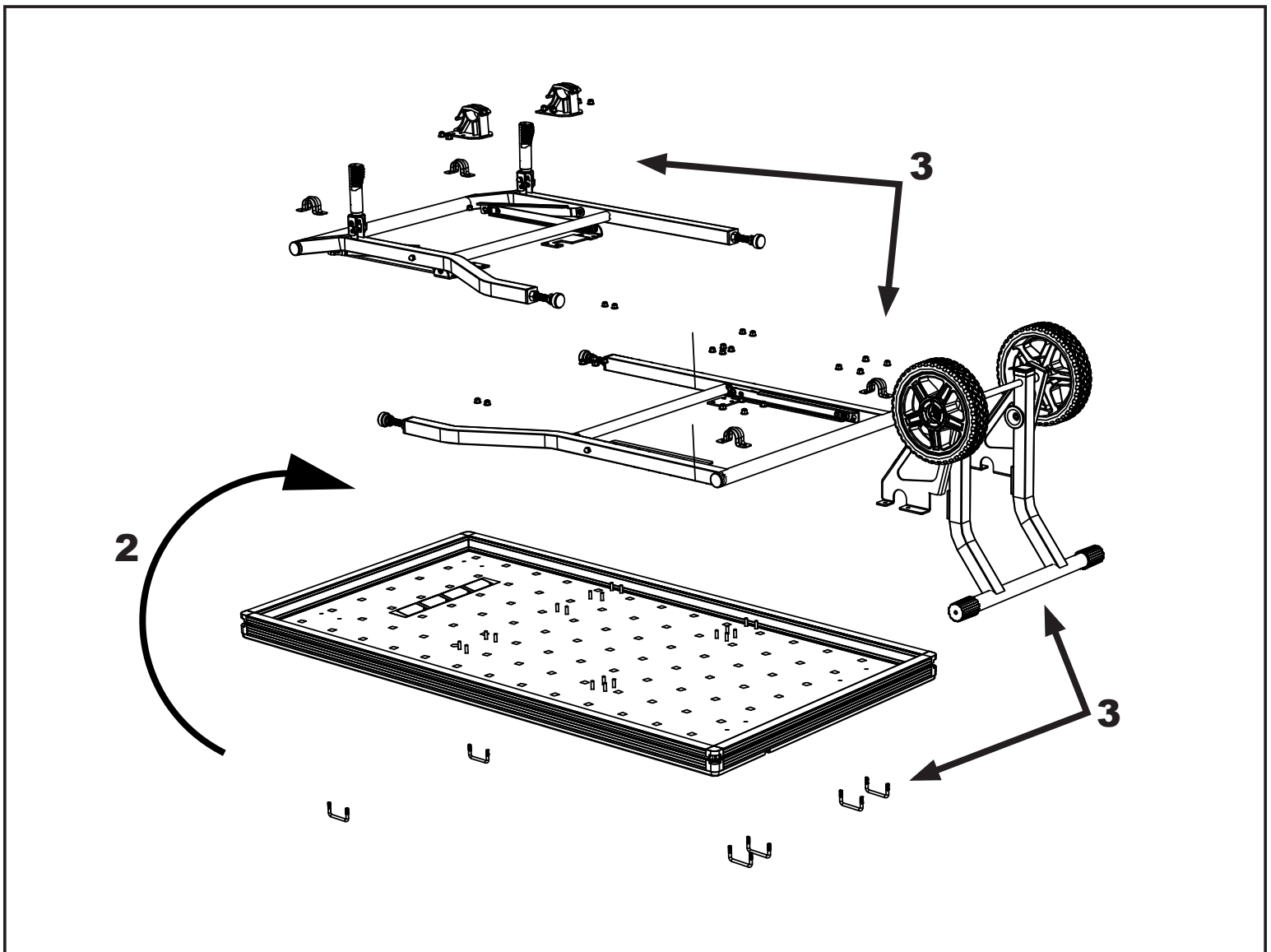
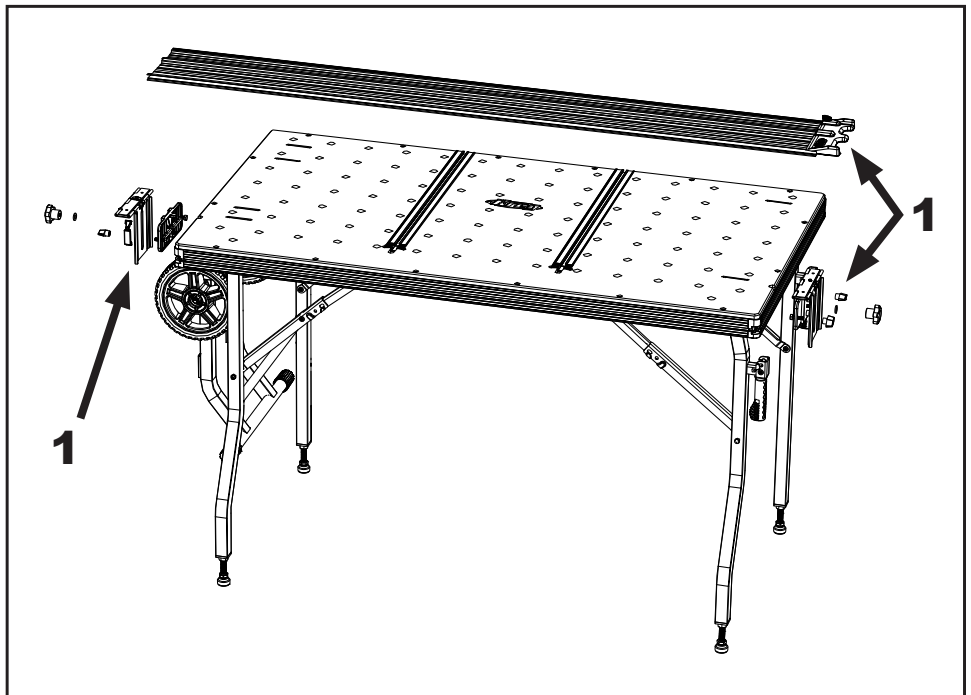

SETUP

Remove the old Project Table Top

- (4) Turn the table top right side up, making sure the table tracks do not fall out and get damaged.
- (5) Lift the table tracks out of the table-top slots. Leave the table-track bolts and plastic retaining plates in place.
- (6) Mark the table frame member adjacent to the side of the table with the saw kerf (cutting side).
- (7) Remove the 16 screws securing the table top to the aluminum frame using the included star-drive bit and remove the top. Discard the screws.

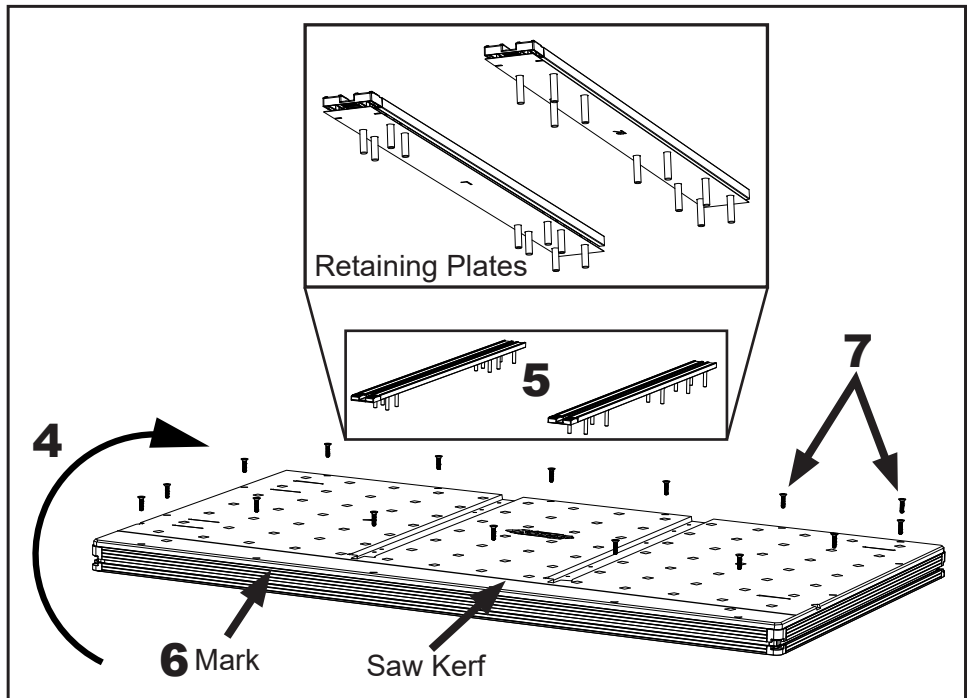

Installing the Project Table Top

- (1) Position the new table top in the aluminum frame with the cutting side of the top on the side opposite the mark on the frame.

⚠ ATTENTION: Rotating the new table top 180° from the position of the old top avoids driving the new table-top bolts into the aluminum frame at the same locations where the old bolts were removed, ensuring secure anchorage.

- (2) Drive the 16 new table-top screws to attach the new table top to the aluminum frame.
- (3) Position the table tracks in the slots.

⚠ ATTENTION: Different bolt spacing allows the table tracks to be installed only in one orientation.

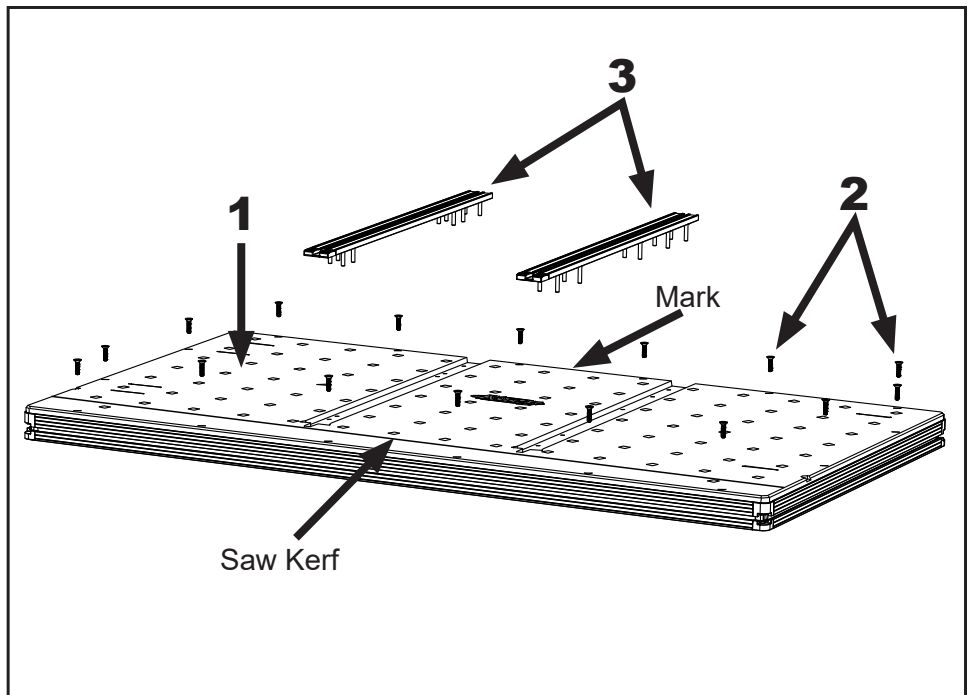

SETUP

Install the Leg and Wheel Assemblies

(1) Turn the project table upside down on a flat surface, making sure the table tracks do not fall out.

(2) Thread nuts onto the two protruding bolts closest to the aluminum frame that fasten each of the table tracks.

⚠ ATTENTION: Before tightening the bolts, ensure the table-track ends are flush with the table-top edge.

(3) Install leg assemblies 1 and 2 and the wheel assembly as instructed in your original Adaptive Cutting System Project Table owner's manual.

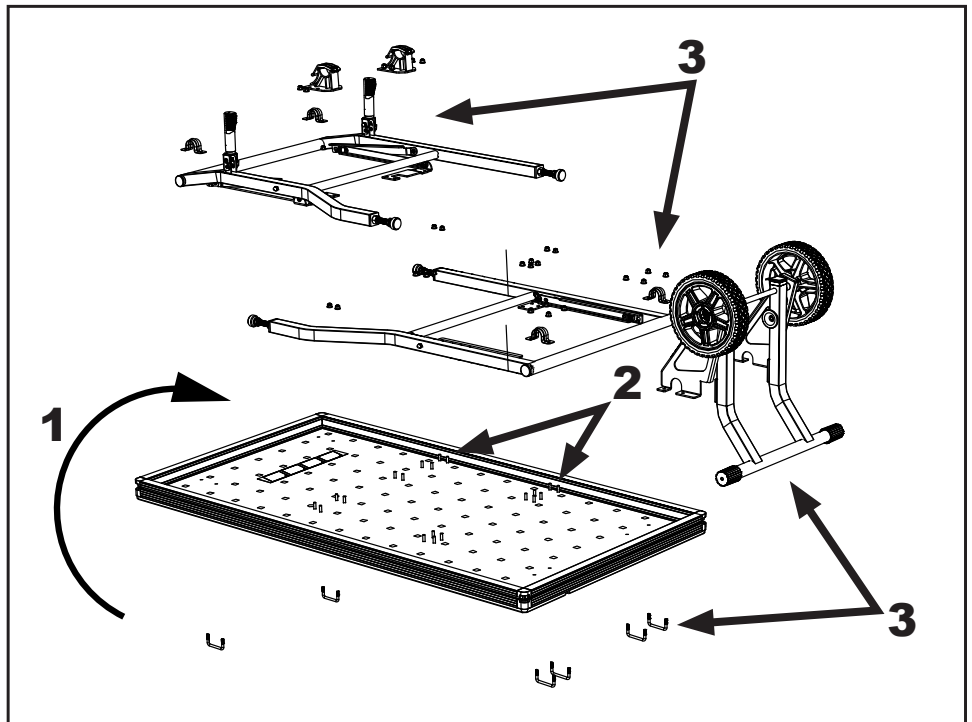

Install the Guide Track

(1) Turn the Project Table right side up and install the hinge-mounting plates, hinges, and guide track, and recalibrate your system as instructed in your original Adaptive Cutting System Project Table owner's manual.

⚠ ATTENTION: Two people are required to lift the Project Table.

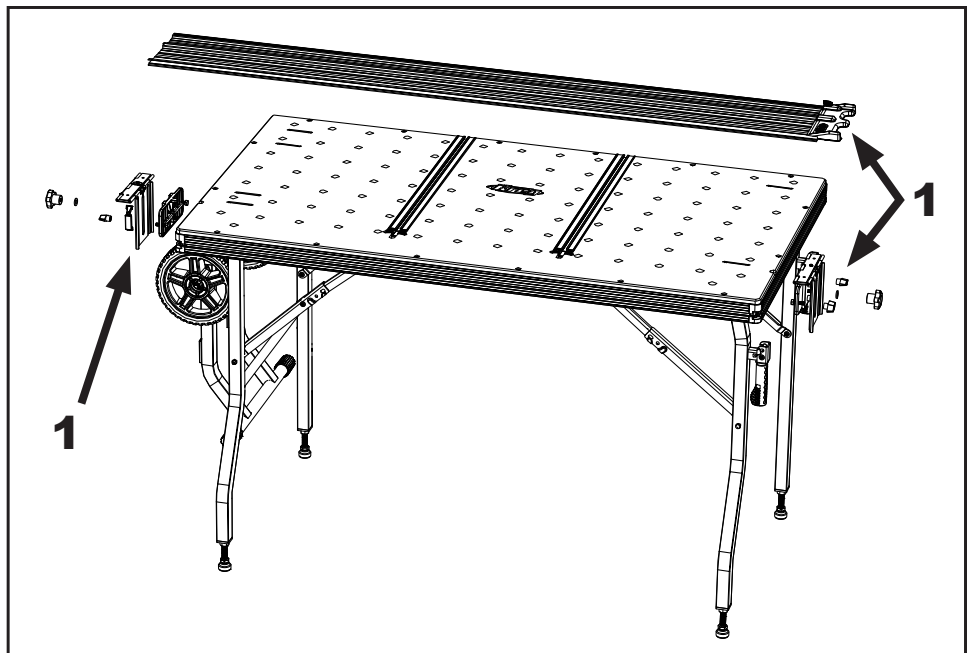

TELL US ABOUT YOUR EXPERIENCE. YOUR OPINION COUNTS.

We're always working to improve Kreg® products and your satisfaction with them so that you have great project-building experiences. You can help by sharing your feedback at www.kregtool.com/feedback. It only takes a couple of minutes, and will help us to create products and support that serve your needs better.

PARLEZ-NOUS DE VOTRE EXPÉRIENCE. VOTRE OPINION EST IMPORTANTE POUR NOUS.

Nous cherchons toujours à améliorer les produits Kreg® et à nous assurer que vous soyez satisfait lorsque vous les utilisez pour effectuer vos projets de construction afin de rendre votre expérience agréable. Vous pouvez nous aider en nous faisant part de vos commentaires au www.kregtool.com/feedback. Cela ne prend que quelques minutes, et vos commentaires nous aideront à créer des produits et à fournir des services qui répondront mieux à vos besoins.

CUÉNTENOS SOBRE SU EXPERIENCIA. SU OPINIÓN CUENTA.

Siempre trabajamos para mejorar los productos Kreg® y su satisfacción con ellos para que tenga excelentes experiencias de construcción de proyectos. Puede ayudar compartiendo su retroalimentación en www.kregtool.com/feedback. Solo toma un par de minutos y nos estará ayudando a crear productos y brindar un soporte que sirva mejor a sus necesidades.



**www.kregtool.com • 800.447.8638
201 Campus Dr, Huxley, IA 50124
Kreg Enterprises Inc.**

For assistance with any Kreg product, contact us through our Web site or call Customer Service.

Si vous avez besoin d'aide concernant les produits Kreg, communiquez avec nous sur notre site Web ou appelez notre service à la clientèle.

Si requiere asistencia con cualquier producto Kreg, póngase en contacto con nosotros a través del sitio web o llame al Servicio al Cliente.