

Screw Gun Kit

Assembly Instructions

Item# CT6066

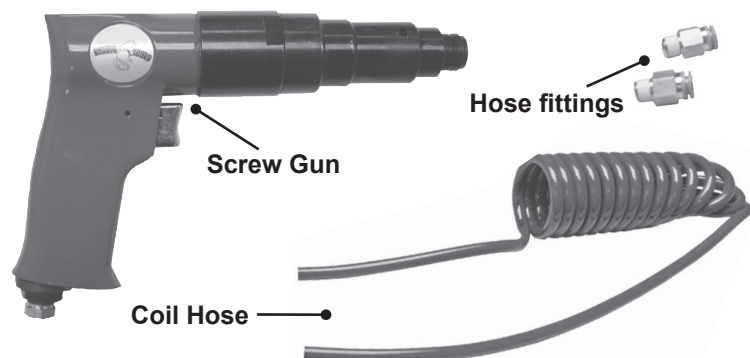

Kit Contains:

- (1) Coil Hose
- (1) Screw Gun
- (2) Hose Fittings
- (1) 6", #2 Square Driver
- (1) Screw Gun Operating Instructions

Tools Needed:

- 1/4" Allen Wrench
- 1/16" Socket or Wrench

WARNING This product contains one or more chemicals known to the State of California to cause cancer and birth defects or other reproductive harm. Wash hands after handling.

Assembly

1 Locate the 1/4" NPT pipe plug on the lower right hand side of the main rail. Remove the pipe plug using a 1/4" allen wrench. Once the pipe plug is removed, thread one of the supplied fittings into the hole. (Note: Thread sealer is already applied to the fitting, no other sealant should be needed. Tighten the fitting using a 1/16" socket or wrench. Do not over tighten!)

2 Remove the screw gun from the box and locate the black plastic (see Fig. 1) cap on the bottom of the handle of the screw gun. Remove this cap and install the second air fitting supplied with this kit into the screw gun using a 1/16" socket or wrench.

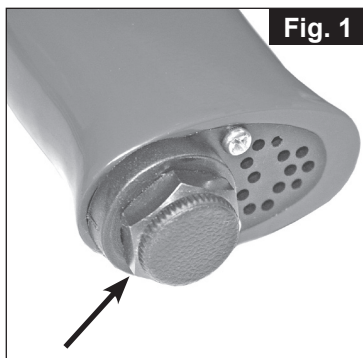

3 Once both fittings are tight, install the blue flexcoil hose to both the main rail and the gun. This is done by simply pushing the hose into the fitting until you feel it seat in the fitting. Now install the 6" driver into the gun and you are ready to start using your screw gun.

4 Store the screw gun in the white PVC-pipe holster attached to the bracket at the bottom of the clamping arm. Due to inconsistency in the wall thickness and internal roundness of the pipe, you may need to remove some material with a half-round file or sandpaper wrapped around a dowel to accommodate the screw gun.

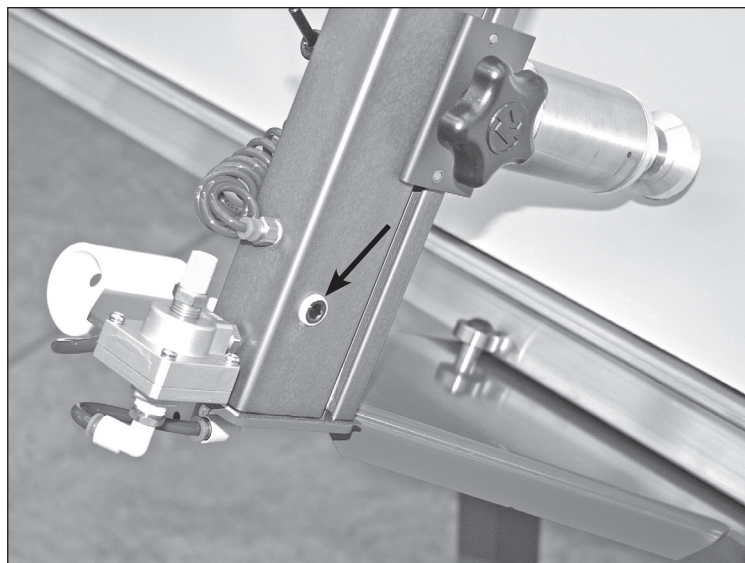

Pipe plug where the hose and gun will attach.

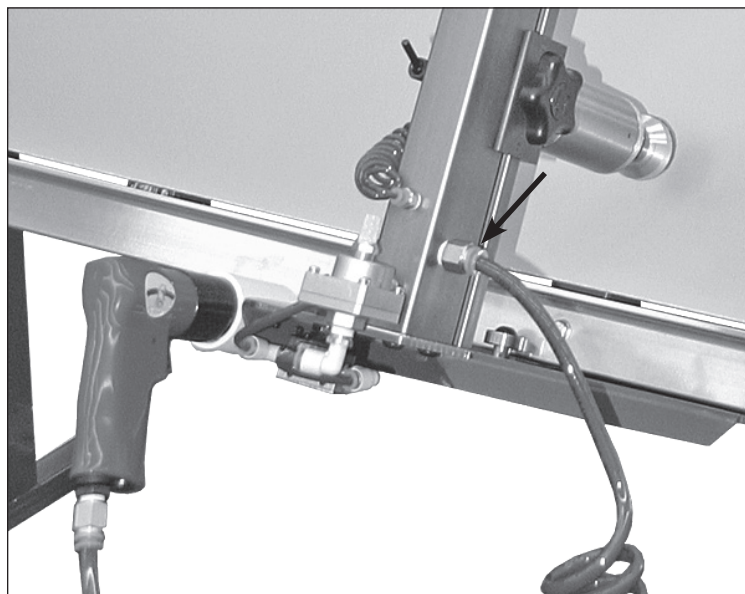

Hose and gun attached to the main rail.

Version 3 - 02/2017