

# Pro Series

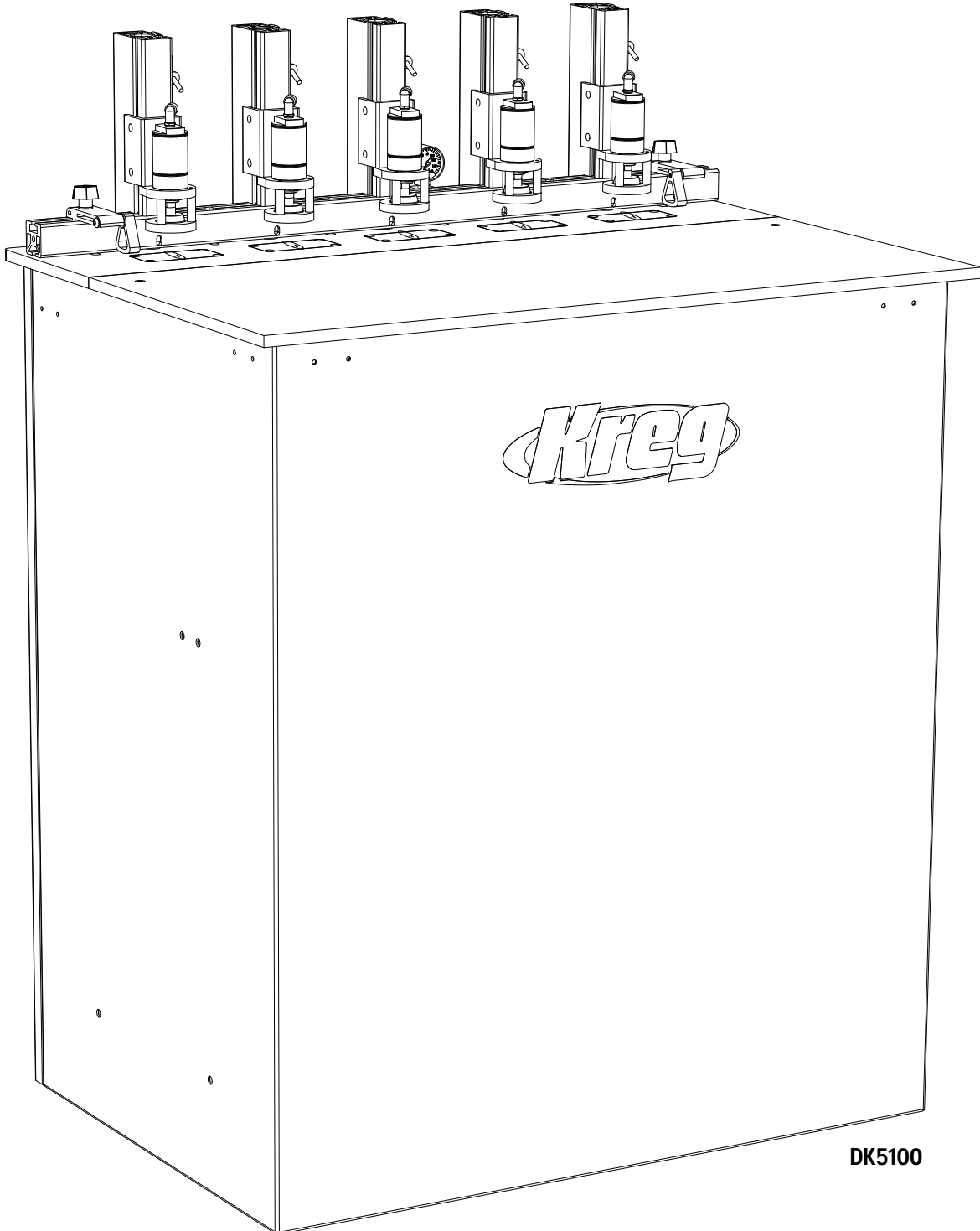

## INSTRUCTIONAL MANUAL

DK5100 Pneumatic Model



DK5100

5/2010 DK5109  
Rev B

**RECOMMENDED AIR PRESSURES:**

**Pneumatic Models: 120 psi**

Congratulations on choosing a Kreg Pro Series Pocket Hole Machine!

Be sure to read the instructions and the safety warnings completely before using this machine.

<i>TABLE OF CONTENTS</i>	1
<i>WARRANTY</i>	2
<i>SAFETY INSTRUCTIONS</i>	3-6
<i>DK5100</i>	
<i>Parts Diagram</i>	7
<i>Quick Start Guide</i>	8
<i>Acrylic Top/Changing Drill Bits/Drill Unit Selection</i>	9
<i>Adjusting the Machine for Stock Thickness</i>	10
<i>Adjusting the Clamp Cylinder Height</i>	
<i>Feed Rate Flow Control/Clamping Duration Control/Swing Stops</i>	11
<i>Air System Pre-Filter/Air System Lubricator</i>	12
<i>Notes</i>	13-14



# WARRANTY

## DK SERIES - FULLY AUTOMATIC POCKET HOLE MACHINES

**PLEASE DO NOT RETURN MACHINE BACK TO DEALER IF WARRANTY ISSUES ARISE. CONTACT KREG TOOL COMPANY AT THE ADDRESS OR PHONE NUMBER BELOW.**

Kreg Tool Company warrants to its authorized distributors of Kreg products and the original purchasers from such distributors, the #DK5100 Pocket Hole Boring Machine to be free of defects in materials and workmanship for a limited 5 year warranty from the date of delivery to the original purchaser. During said warranty period Kreg will, at its option, repair or replace any product (or component part thereof) proving defective during said period. This warranty applies only to products which are used in accordance with all instructions as to operation, maintenance and safety set forth in catalogs, manuals, and/or instruction sets furnished by Kreg Tool Company.

This warranty becomes effective only if the accompanying card or online form ([www.kregtool.com](http://www.kregtool.com)) is fully and properly completed and returned to Kreg Tool Company within ten (10) days from date of delivery to the original purchaser.

The drill guide will carry a lifetime warranty.

This limited warranty of five (5) years does not apply towards the motor and other "working parts" of the machine. These items will carry a one (1) year warranty from the date of delivery to the original purchaser.

This warranty does not apply to items that would normally be consumed or require replacement due to normal wear (drill bits, lubricants, etc.); for the cost of removal of components if such removal is authorized by Kreg Tool Company; for shipment to Kreg Tool Company's repair facility; or for reinstallation.

This warranty is null and void if the product has been subjected to (1) misuse, abuse or improper service or storage; (2) accident, neglect, damage or other circumstances beyond Kreg Tool Company's control; (3) modifications, disassembly, tampering, alterations or repairs outside of Kreg Tool Company's factory not authorized by Kreg Tool Company; (4) to any product not bearing its original serial number plate; and (5) for non-original purchasers. This warranty does not apply to normal wear and tear, corrosion, abrasion, or repairs required due to natural causes or acts of God.

To obtain warranty service contact the distributor from which this Pocket Hole Boring Machine was purchased, or you may contact Kreg Tool Company directly. Proof of purchase will be required before remedy will be provided under the terms of this warranty. Kreg Tool Company assumes no responsibility for products which are returned without prior authorization. Kreg Tool Company's obligations under this warranty shall be exclusively limited to repairing or replacing (at Kreg Tool Company's option) products which are determined by Kreg Tool Company to be defective upon delivery at Kreg Tool Company's factory, and on inspection by Kreg Tool Company. Under no circumstance shall Kreg Tool Company be liable for incidental or consequential damages resulting from defective products, nor shall Kreg Tool Company's liability exceed the purchase price paid for the product by the original purchaser.

This is Kreg Tool Company's sole warranty. Any and all other warranties which may be implied by law, including any warranties for merchantability or fitness for a particular purpose, are hereby limited to the duration of this warranty. Kreg Tool Company shall not be liable for any loss, damage or expense directly or indirectly related to the use of its products or from any other cause or for consequential damages (including without limitation, loss of time, inconvenience, and loss of production). The warranty contained herein may not be modified and no other warranty, expressed or implied, shall be made by or on behalf of Kreg Tool Company.

**Please register your warranty by sending warranty registration card. Warranty service will not be provided without registration.**

**Keep a copy of this form for your records.**

**For your records the following information will be useful in the event warranty service is required. For complete records attach copy of purchase invoice to this form.**

**Date of Purchase:** \_\_\_ / \_\_\_ / \_\_\_

**Purchased From:** \_\_\_\_\_

**Serial Number:** \_\_\_\_\_

(serial number is located on front edge of work surface plate)



### Warnings:

- Do not operate this machine without the acrylic top securely fastened into place using the provided lock-down screws. Doing so will increase your chances of injury or death.
- Woodworking machines are dangerous, and can cause personal injury if not used properly.
- Read safety instructions and operating instructions for your machine completely, before using products. Using this system before understanding its safe and proper use could result in serious injury to the operator.
- Failure to follow these rules may result in serious personal injury.
- For your own safety, read the instruction manual before operating the tool. Learn the tool's application and limitations as well as the specific hazards distinctive to it.
- Keep all guards and safety devices in proper place while using these products.
- Always wear safety glasses.
- Keep hands well away from the pneumatic clamp and rotating bit when operating the machine.
- Avoid awkward hand positions, where a sudden slip could cause contact with the rotating bit. Never reach under the pneumatic clamp pad with either hand to hold down the workpiece.
- As with all machinery, there are certain hazards involved with the operation and use of the machine. Using the machine with respect and caution will considerably lessen the possibility of personal injury. However, if normal safety precautions are overlooked or ignored, personal injury to the operator may result.
- This system was designed for certain applications only. Kreg strongly recommends that this system NOT be modified and/or used for any application other than for which it was designed. If you have any questions relative to its application, DO NOT use the machine until you have written, phoned, or e-mailed Kreg Tool and have been advised accordingly.
- Be aware of kickbacks. Kickbacks occur when the workpiece binds-up while being drilled, causing it to twist, jump, and possibly become airborne. To avoid kickbacks (and potential injury) always use sharp drill bits, keep the machine aligned and maintained properly, and adequately secure/support the workpiece.
- Turn machine off before adjusting. Never adjust the fence, swing stop, clamping cylinder, depth stop, drill bit, or any other part of the machine while it is running.
- Wait for the machine to stop. Make sure the drill comes to a complete stop before adjusting the workpiece or workpiece-angle.
- Ground electric machines. If your machine is equipped with a three-prong plug, it should be plugged into a three-hole electrical receptacle only. If the proper outlet is not available, have one installed by a qualified electrician before use. Never remove the third prong, and never modify the provided plug in any way.
- Remove adjusting keys and wrenches. Be sure to check that all adjusting keys and wrenches are removed from the machine before turning it on.
- Don't operate in a dangerous or unclean environment. Don't use power tools in damp or wet locations, or expose them to rain. Keep work area well-lit, un-cluttered, and clean.
- Keep children and visitors away. All children and visitors should be kept a safe distance from the work area, and should not operate the machine under any condition.
- Make your workshop "child-proof". Use padlocks, master switches, or any other means necessary to make your work area safe for children.
- Use the right tool. Never 'force' the tool to do work for which it was not intended. If used properly, the tool will produce better results in less time, under safer conditions.
- Wear proper apparel. No loose clothing, gloves, neckties, rings, bracelets, or any other jewelry that could possibly get caught in moving parts. Non-slip footwear is highly recommended, as is protective hair covering. Remember to always use safety glasses, specifically designed as safety wear.
- Secure the workpiece. Use clamps or a vise to hold work when it is practical and safe. Using the proper tool may allow you to free both hands for tool operation. Also, be sure to never overreach.

## Warnings:

- Secure your tools. In the event of the machine tipping or sliding, it is always recommended to secure your tools to the machine, or in another safe location, during use.
- Keep the proper footing and balance. Ensure that you are in no danger of slipping or sliding once you turn the machine on. Once again, non-slip footwear is highly recommended.
- Maintain tools in top condition. Keep tools sharp, clean, and properly maintained for the highest quality and safest performance. Remember to properly follow all lubrication and accessory maintenance practices, as detailed in this Instruction Manual.
- Disconnect tool before servicing. When changing accessories such as bits, clamps, etc., making any sort of physical assessment of the tool, or when motor is being mounted/connected, remember to disconnect the machine from its power source. This will reduce the possibility of accidentally engaging the machine.
- Use recommended accessories only. Use of any additional accessories (add-ons) is strictly at your own risk. This machine was designed with only the use of Kreg certified parts in mind. Use of uncertified accessories may be hazardous.
- Avoid accidental starting. Make sure power switch is positioned at "OFF" and that no one is located near the machine, before plugging in the power cord.
- Never stand on the machine. Serious injury could occur if the machine is tipped or if the cutting tool is contacted. Do not stand on top of the machine for any reason.
- Check for damaged parts. Before use of the machine, a careful assessment of all guards and other parts should be made to ensure that it will operate properly, and perform as intended. Check for alignment of moving parts, binding of moving parts, breakage of parts, mounting, and any other conditions that may affect its operation. A guard or other part that is damaged should be properly repaired or replaced as soon as possible, preceding any additional use. Do not use the machine if you are not qualified to make these sorts of assessments.
- Never leave a running machine unattended. Always turn the machine's power "OFF" after operation. Do not leave the tool until it comes to a complete stop.
- Drugs, alcohol, medication warning. Do not operate tool while under the influence of drugs, alcohol, or any medications.
- For additional security, this machine's power switch can be 'locked out' to prevent unintentional power-on. To do so, place a lock out device through the round opening behind the green switch. Please note, this is not to be used as an alternative to unplugging the machine during repairs.

**WARNING:** This product contains one or more chemicals known to the State of California to cause cancer and birth defects or other reproductive harm. **Wash hands after handling.**

**WARNING:** Some dust created by power sanding, sawing, grinding, drilling, and other construction activities contains chemicals known to the State of California to cause cancer and birth defects or other reproductive harm.

Some examples of these chemicals are:

- lead from lead-based paints,
- crystalline silica from bricks and cement and other masonry products,
- arsenic and chromium from chemically treated lumber.

Your risk from exposure to these chemicals varies, depending on how often you do this type of work. To reduce your exposure, work in a well-ventilated area and with approved safety equipment, such as dust masks that are specially designed to filter out microscopic particles.

**WARNING:** The wire of this product contains chemicals known to the State of California to cause cancer and birth defects or other reproductive harm. Wash hands after handling.

### Avertissements :

- Les machines à travailler le bois sont dangereuses et peuvent causer des blessures corporelles s'ils ne sont pas utilisées correctement.
- Lisez complètement les consignes de sécurité et le mode d'emploi de la machine avant d'utiliser les produits. Utiliser ce système avant d'en comprendre son utilisation correcte et sécuritaire peut causer des blessures graves à l'opérateur.
- Ne pas se conformer à ces règles peut entraîner des blessures corporelles graves.
- Pour votre propre sécurité, lisez le manuel de l'utilisateur avant d'utiliser l'outil. Prenez connaissance des applications et des limites de l'outil, de même que des dangers spécifiques qui lui sont propres.
- Laissez tous les dispositifs de sécurité à leur place lorsque vous utilisez ces produits.
- Portez toujours des lunettes de sécurité.
- Gardez les mains loin de la pince pneumatique et de l'embout rotatif lorsque vous utilisez la machine.
- Évitez de placer vos mains de façon inconfortable, où elles pourraient glisser soudainement et entrer en contact avec l'embout rotatif. Ne passez jamais une main sous la plaque de la pince pneumatique pour maintenir en place la pièce.
- Comme pour tout équipement, l'utilisation de la machine comporte certains risques. Utiliser la machine avec respect et prudence diminue considérablement les risques de blessures corporelles. Toutefois, ne pas tenir compte ou ignorer les précautions d'usage peut entraîner des blessures corporelles à l'opérateur.
- Ce système a été conçu pour certaines applications seulement. Il est fortement recommandé par Kreg de NE PAS modifier et/ou utiliser ce système pour des applications autres que celles pour lesquelles il a été conçu. Si vous avez des questions concernant son application, N'UTILISEZ PAS la machine avant d'avoir écrit, appelé ou contacté par courriel Kreg Tool et que vous ayez été conseillé relativement à ces questions.
- Méfiez-vous des rebonds. Il y a rebond lorsque la pièce se coince pendant qu'on la perce; elle se tord, saute et peut possiblement être projetée. Afin d'éviter les rebonds (et des blessures potentielles), utilisez toujours des forets bien aiguisés, entretenez bien la machine et maintenez son alignement, et fixez ou supportez bien la pièce.
- Éteignez la machine avant d'effectuer des ajustements. N'ajustez jamais le guide, le dispositif anti oscillation, le cylindre de serrage, la butée de profondeur de mortaise, le foret ou tout autre élément de la machine pendant qu'elle est en marche.
- Attendez l'arrêt complet de la machine. Assurez-vous que le foret soit complètement arrêté avant d'ajuster la pièce ou l'angle de la pièce.
- Mettez les machines électriques à la terre. Si la machine est munie d'une fiche à trois broches, elle doit uniquement être branchée à une prise de courant à trois trous. S'il n'y a pas de prise adéquate disponible, faites en installer une par un électricien qualifié avant usage. N'enlevez jamais la troisième broche et ne modifiez jamais la fiche fournie en aucun cas.
- Enlevez les clavettes de calage et les clés de réglage. Assurez-vous qu'il ne reste aucune clavette de calage ou clé de réglage avant d'allumer la machine.
- N'utilisez pas le produit dans des environnements dangereux ou sales. N'utilisez pas d'outils électriques dans des endroits humides et ne les exposez pas à la pluie. Gardez l'espace de travail bien éclairé, rangé et propre.
- Maintenez les enfants et les visiteurs à l'écart. Tous les enfants et les visiteurs doivent demeurer à une distance sécuritaire de l'espace de travail et ne doivent en aucun cas utiliser la machine.
- Ayez un atelier « à l'épreuve des enfants ». Utilisez des cadenas, des interrupteurs principaux ou tout autre moyen nécessaire pour que votre espace de travail soit sécuritaire pour les enfants.
- Utilisez les outils adéquats. Ne « forcez » jamais un outil à effectuer un travail pour lequel il n'a pas été conçu. Si l'outil est utilisé correctement, vous obtiendrez de meilleurs résultats en moins de temps et dans des conditions sécuritaires.
- Portez des habits adéquats. Pas de vêtement ample, de gant, de cravate, de bague, de bracelet ou autres bijoux pouvant se prendre dans des pièces mobiles. Le port de chaussures à semelle antidérapante est fortement recommandé, de même qu'une coiffure antiscalp. Souvenez-vous de toujours porter des lunettes de sécurité spécialement identifiées en tant qu'accessoire de sécurité.
- Ancrez bien la pièce. Utilisez des pinces ou un étau pour maintenir la pièce en place lorsque cela est pratique et sécuritaire. Employer l'outil adéquat peut vous permettre de libérer vos deux mains pour utiliser l'outil. Assurez-vous également de ne jamais tendre les bras trop loin.

## Avertissements :

- Ancrez bien les outils. Advenant que la machine bascule ou glisse, il est toujours recommandé de bien ancrer les outils à la machine, ou à un autre endroit sécuritaire, pendant l'opération.
- Placez les pieds de façon à garantir l'équilibre. Assurez vous de ne pas courir le risque de glisser une fois la machine en marche. Encore une fois, le port de chaussures à semelle antidérapante est fortement recommandé.
- Maintenez les outils en état optimal. Gardez les outils bien tranchants, propres et bien entretenus pour obtenir une performance de la plus grande qualité et des plus sécuritaires. Souvenez vous de suivre correctement les techniques de lubrification et d'entretien des accessoires, détaillées dans le présent manuel de l'utilisateur.
- Débranchez l'outil avant d'effectuer l'entretien. Souvenez vous de débrancher la machine de sa source d'alimentation lorsque vous changez des accessoires, comme les forets, les pinces, etc., lorsque vous évaluez physiquement un outil ou lorsque le moteur est en train d'être monté ou branché. Cela diminuera les chances de mettre en marche accidentellement la machine.
- Utilisez uniquement les accessoires recommandés. L'utilisation d'accessoires supplémentaires (extensions) est strictement à vos propres risques. Cette machine a été conçue uniquement en fonction de pièces certifiées Kreg. L'emploi d'accessoires non certifiés peut s'avérer dangereux.
- Évitez les mises en marche accidentelles. Assurez vous que l'interrupteur est à la position d'arrêt (« OFF ») et qu'il n'y a personne à proximité de la machine avant de brancher le cordon d'alimentation.
- Il ne faut jamais se tenir debout sur la machine. Des blessures graves peuvent survenir si la machine bascule ou s'il y a contact avec l'outil de coupe. Ne vous tenez en aucun cas debout sur la machine.
- Vérifiez s'il y a des pièces endommagées. Avant d'utiliser la machine, il faut évaluer avec soin tous les dispositifs de sécurité et les autres pièces pour garantir que la machine fonctionnera convenablement. Vérifiez l'alignement des pièces mobiles, le montage et s'il y a des pièces mobiles grippées ou des pièces brisées, ainsi que toutes les autres conditions pouvant influencer son fonctionnement. Un dispositif de sécurité ou toute autre pièce endommagée doit être réparée ou remplacée convenablement dès que possible, avant tout autre usage. N'utilisez pas la machine si vous n'êtes pas qualifié pour effectuer ce genre d'évaluation.
- Ne laissez jamais une machine en marche sans surveillance. Coupez toujours l'alimentation de la machine une fois l'opération terminée. Ne quittez pas l'outil avant qu'il ne soit complètement arrêté.
- Avertissement quant aux drogues, à l'alcool et aux médicaments. N'utilisez pas l'outil avec les facultés affaiblies par la drogue, l'alcool ou les médicaments.
- Pour la sécurité additionnelle, le commutateur de puissance de cette machine peut être 'fermé à clef dehors' pour empêcher l'allumage involontaire. Pour faire ainsi, placez un dispositif de serrure dehors par l'ouverture ronde derrière le bouton d'allumage vert. Notez s'il vous plaît, ceci ne doit pas être employée comme alternative à débrancher la machine pendant les réparations.

**ADVERTENCIA:** Este producto contiene una o más sustancias químicas reconocidas por el estado de California como causantes de cáncer y defectos congénitos u otros daños en el aparato reproductivo. **Lávese las manos después de manipularlo.**

**ADVERTENCIA:** Parte del polvo causado por el lijado eléctrico, el serruchado, la trituración, la perforación y otras actividades de construcción contiene químicos que, según el estado de California, causan cáncer, defectos de nacimiento u otros daños en el aparato reproductivo.

Algunos ejemplos de estos químicos son:

- plomo de pinturas a base de plomo,
- sílice cristalina de ladrillos, cemento y otros productos de mampostería,
- arsénico y cromo de la madera tratada con químicos.

El riesgo que corre debido a la exposición a estos químicos varía dependiendo de la frecuencia con que realiza este tipo de trabajo. Para reducir su exposición a estas sustancias químicas, trabaje en un área bien ventilada y utilice un equipo de seguridad aprobado, como las máscaras para polvo especialmente diseñadas para filtrar partículas microscópicas.

**ADVERTENCIA:** El cable de este producto contiene sustancias químicas reconocidas por el estado de California como causantes de cáncer y defectos congénitos u otros daños en el aparato reproductivo. **Lávese las manos después de manipularlo.**

### DK1100 FE - Electric Model Parts Diagram

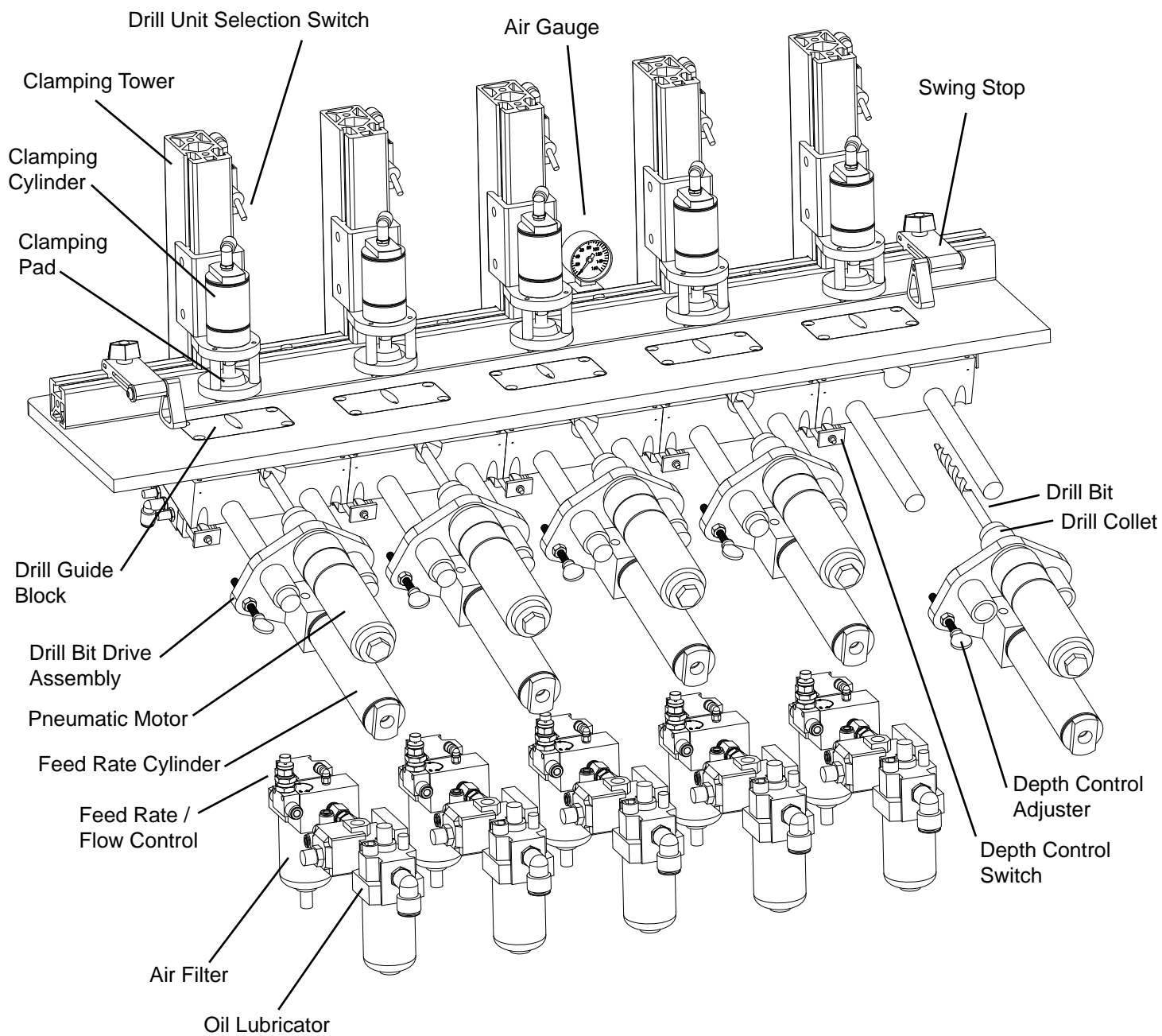

## DK5100 QUICK START GUIDE

- Depending on the frequency of use, Kreg recommends that you grease the planetary gear on the pneumatic drill at least once per month. To grease, use the needle-point zerk fitting (included with your machine), and a couple of pumps of Sta-Lube Extreme Pressure Moly-Graph® Multi-Purpose Grease, (1.800.272.8963 [www.fastenal.com](http://www.fastenal.com)), or equivalent. As shown at right, you may need to rotate the drill to gain access to the grease zerk. If so, use a crescent wrench to rotate the black fitting at the rear of the drill clockwise, until you have access to the grease zerk. **Remember to disconnect all air supply before working on machine.**

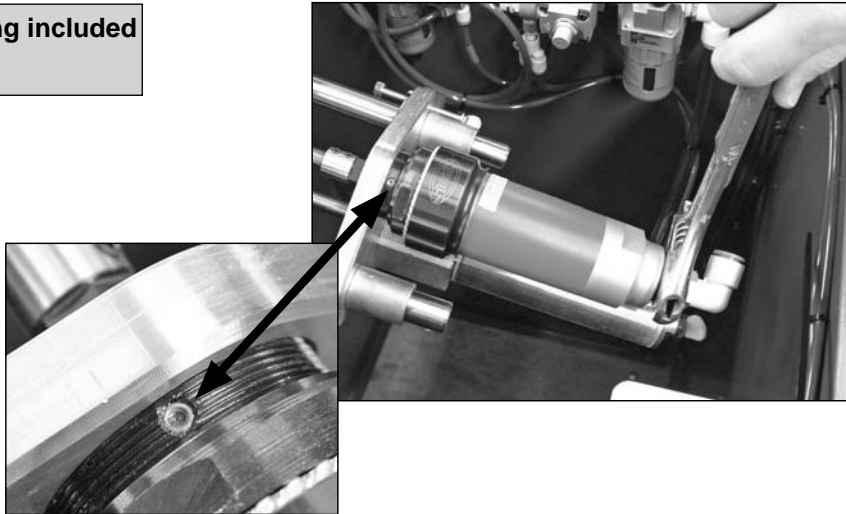
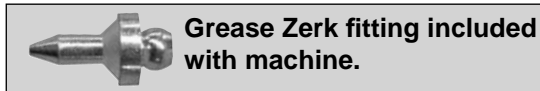

### Acrylic Top Must Be Secured

Do not operate this machine without the acrylic top positioned correctly and secured with the two provided lock-down screws (1/8" allen wrench provided). Running the machine without the top in place and properly secured increases your chance of injury and is not recommended under any circumstance.

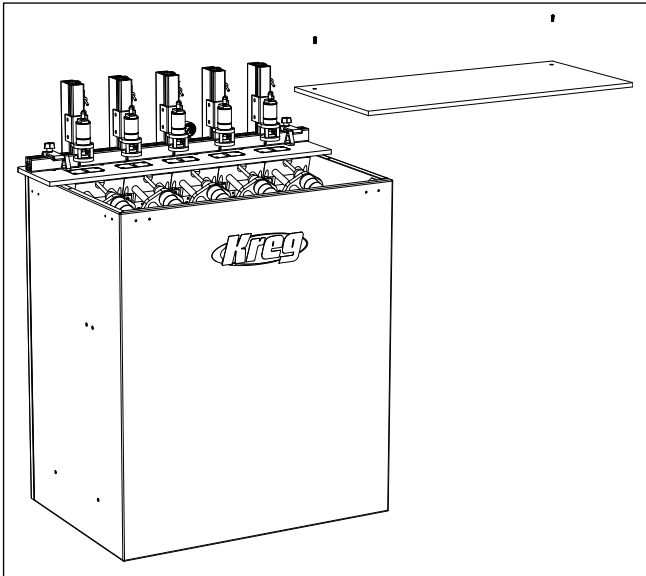

### Drill Unit Selection

The DK5100 machines were designed for multiple pocket hole drilling for applications normally associated with carcass construction. The DK5100 will drill up to five pocket holes at 6-inch centers across a 24-inch span. Each of the Drill Units can be independently selected via the Drill Unit Selector Switch. This simple "ON/OFF" switch will enable or disable the associated Drill Unit's operation. By selecting Drill Units to "OFF" that Drill Unit will not actuate during the drilling cycle. This option will allow the operator to vary the pocket hole spacing in increments of 6-inch and 8-inch spacing depend on the model. For example: You could drill four pocket holes in a 28-inch panel with two holes spaced 2-inches from the each end and 6-inches apart by switching the middle Drill Unit to "OFF" on a DK5100 machine.

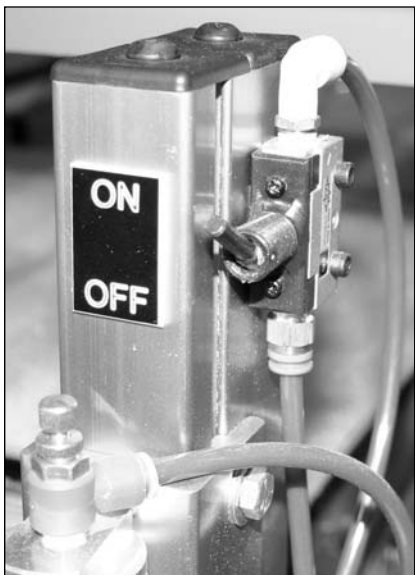

### Changing Drill Bits

You can expect to drill between 4000 and 5000 holes in Oak with your #DKDB drill bit before the bit will need to be sharpened. This baseline was established using the factory settings described in the owner's manual. Adjust your sharpening schedule for your settings and the material that you may be drilling.

### IMPORTANT!

Before changing the drill bit, make certain your machine is DISCONNECTED from the AIR SUPPLY. Cycle the machine via the foot switch several times to remove air from the system. Without an air supply you can be certain the bit will not accidentally engage while you are performing maintenance.

- Step 1:** Disconnect the machine from the power supply.
- Step 2:** Remove the black acrylic top to gain access to the inside of the machine.
- Step 3:** Use included wrenches to loosen collet (as shown below)
- Step 4:** Remove the Drill Bit by pushing forward out of the Drill Chuck and into the Drill Guide Plate until the Drill Bit clears the Drill Collet. Angle the Drill Bit slightly and pull clear of the Drill Guide Plate.
- Step 5:** Insert a new or re-sharpened Drill Bit into the Drill Chuck, aligning the flats on the Drill Bit shank with the jaws of the Drill Collet.
- Step 6:** Re-attach black acrylic top and power supply.

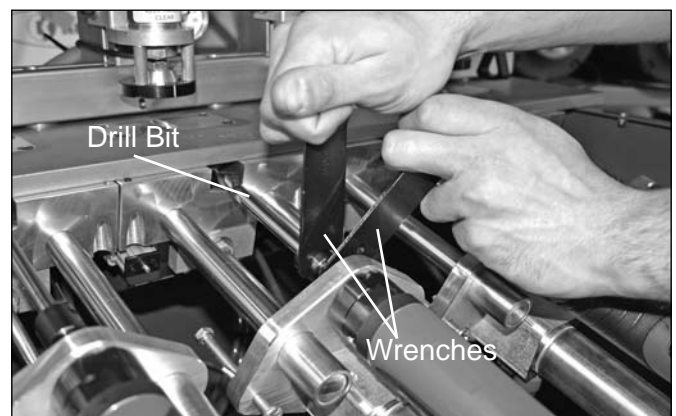

## Adjusting the Machine For Stock Thickness

### A) Adjusting the Fence Setting

The Fence can be adjusted to align the pocket hole to the center of material of different thicknesses. When adjusting the Fence make sure that the Fence remains perpendicular to the Guide Plate. A Reference Scale has been provided to approximate the fence setting for 1/2", 3/4", and 1-1/2" thick material. These correspond to the "A", "B", and "C" lines on the Reference Scale.

- Step 1: Loosen the (4) Socket-head Cap Screws contained below the surface of the Fence.
- Step 2: Align the Fence perpendicular to the Guide Plate for the setting that corresponds to the material thickness.
- Step 3: Tighten the (4) Socket-head Cap Screws to lock the Fence into position.

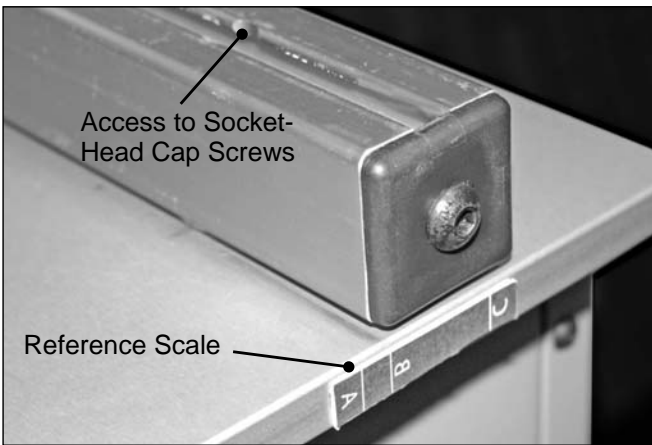

**Setting "A" = 1/2" Material\***

**Setting "B" = 3/4" Material\***

**Setting "C" = 1-1/2" Material\***

\*Approximate fence setting.

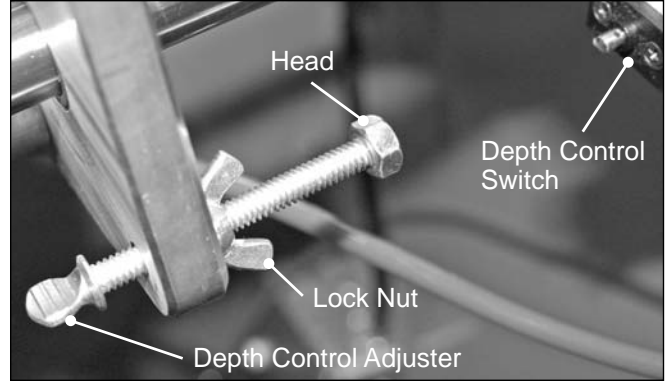

### B) Adjusting the Drill Bit Depth Stop

A Drill Bit Depth Stop is provided to stop the Drill Bit forward motion and control the Drill Feed Cylinder cycle. When the head of the Drill Bit Depth Stop fully engages the Depth Control Switch the forward motion of the Drill Bit is stopped and reversed to complete the drilling cycle. Before adjusting the Drill Bit Depth Stop make certain your machine is **DISCONNECTED** from the **AIR SUPPLY** and/or **ELECTRICAL SUPPLY**. Cycle the machine via the foot switch several times to remove air from the system. Without an air supply or electrical supply you can be certain the machine will not accidentally engage while you are performing maintenance.

- Step 1: Loosen the Lock Nut on the Depth Control Adjuster. Adjust the Depth Control Adjuster the approximate position.
- Step 2: Push the Drill Bit Drive Assembly forward until the Drill Bit pilot point is slightly away from the Fence. For 1/2" and 3/4" material, push your drill bit up to be approximately 1/8" from the tip to the edge of the fence. For 1-1/2" material, push your drill bit up to be approximately 1" from the tip to the edge of the fence.



Shown for use with 1/2 & 3/4" Settings.

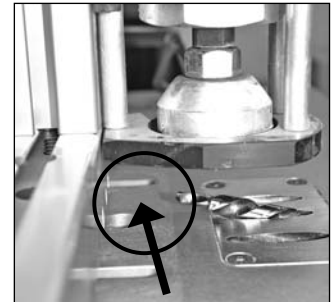

Shown for use with 1-1/2" Setting.

- Step 3: Adjust the Drill Depth Control Adjuster until the Head fully depresses the plunger on the Depth Control Switch.
- Step 4: Tighten the Lock Nut to lock the Depth Control Adjuster in position.
- Step 5: Pull the Drill Bit Drive Assembly back into the resting position.

**NOTE: Always remember as your drill bit gets shorter from sharpening, that you will need to compensate for that distance too.**

### Adjusting the Clamping Cylinder Height

The Clamping Cylinder can be adjusted for material of different thicknesses. The factory setting will clamp materials of approximate thicknesses between 1/2" and 3/4". For materials thicker than 7/8", the Clamping Cylinder will need to be moved upward to allow the material to locate below the Clamp Pad. Before adjusting the Clamping Cylinder make certain your machine is DISCONNECTED from the AIR SUPPLY. Cycle the machine via the foot switch several times to remove air from the system. Without an air supply or electrical supply you can be certain the Clamping Cylinder will not accidentally engage or the drill bit will not rotate while you are performing maintenance.

- Step 1: Loosen the (4) Socket-head Cap Screws (two on each side) located on the Clamping Cylinder Bracket.
- Step 2: Adjust the Clamping Cylinder to allow the material to pass under the Clamp Pad.
- Step 3: Tighten the (4) Socket-head Cap Screws to lock the Clamping Cylinder in position.

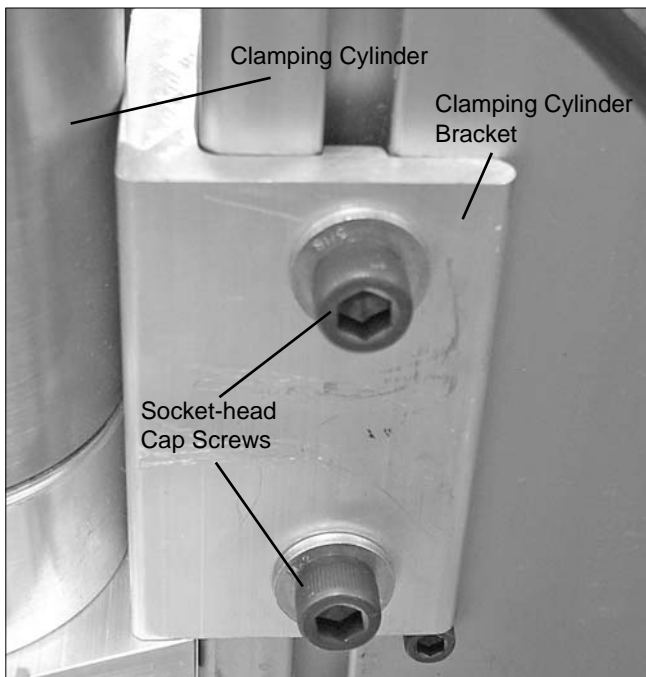

### Swing Stops

Two Swing Stops are provided to assist in drilling pocket holes in the same location on multiple work pieces of the same dimension. When the Swing Stop is not used, it will pivot out of the way to allow the work piece to slide underneath and rest against the fence. To change the location of the Swing Stop simply loosen the Knob, move to the new location and tighten the Knob to lock the Swing Stop in position.

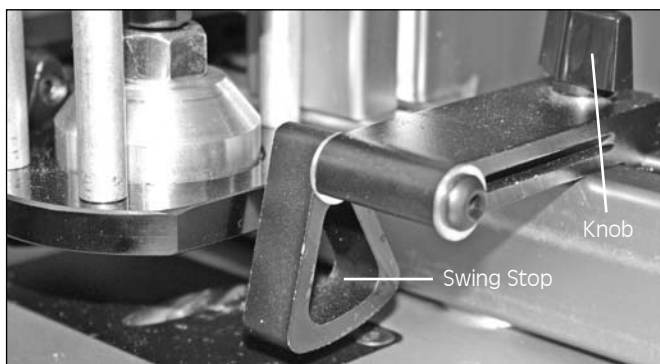

### Feed Rate Flow Control

The Feed Rate Control Valve allows the user to adjust the speed at which the drill bit advances into the material. The factory setting of this valve will maintain a consistent feed rate for various thicknesses of different materials to optimize Drill Bit life. The Feed Rate Control Valve should only be adjusted when a faster or slower rate of Drill Bit feed is desired. This adjustment is only recommended for experienced users that consistently drill the same thickness of the same type of material on a daily basis. The Feed Rate Control Valve is adjusted by loosening the Locking Collar and rotating the Screw in the direction of the desired change in feed rate. "F" corresponds to a Faster feed rate, "S" corresponds to a Slower feed rate. Make certain to tighten the Locking Collar to prevent the Screw from accidentally drifting or vibrating out of adjustment.

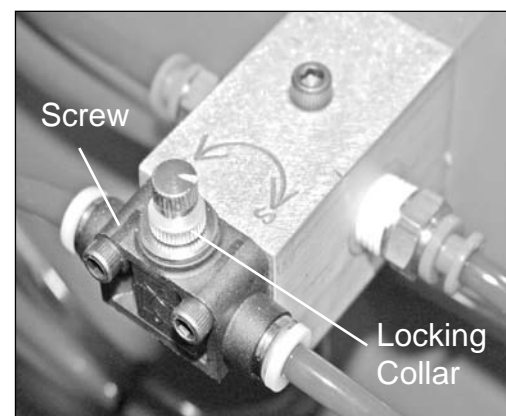

### Clamping Duration Control

Clamping Duration Control allows the user to adjust the duration that the pneumatic clamp engages the material before, during, and after the drilling operation is performed. The factory setting of this valve will maintain the correct amount of time that the material is clamped while drilling. If the work piece lifts off of the Drill Guide Plate during drilling then the Clamping Duration Control will need to be adjusted. Loosen the Locking Collar and turn the Screw in the clockwise direction to increase the duration (more clamping time). Turning the Screw in the counter-clockwise direction decreases the duration (less clamping time). Make certain to tighten the Locking Collar to prevent the Screw from accidentally drifting or vibrating out of adjustment.

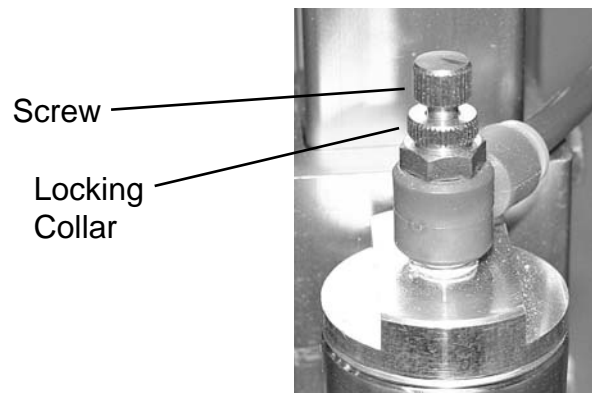

### ***Air System Prefilter***

An Air System Prefilter is provided to maintain a clean, moisture-free supply of compressed air to the machine. The Air System Prefilter reservoir should be routinely drained of moisture. To drain moisture from the reservoir either push the drain valve up toward the reservoir or to the side to use system air pressure to drain the collected fluid. If the Air System Prefilter reservoir needs to be removed to clean or replace the filter, make certain your machine is DISCONNECTED from the AIR SUPPLY. Cycle the machine via the foot switch several times to remove air from the system.

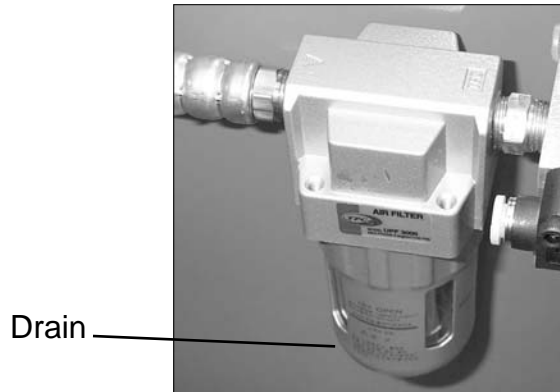

### ***Air System Lubricator***

An Air System Lubricator is provided to maintain proper lubrication to the pneumatic motors. The Air System Lubricator is filled with air motor oil and the Air System Lubricator comes preset at 1/2 turn open. The oil level in the Air System Lubricator should be routinely checked and refilled with air motor oil comparable to the oil provided. Normal use of the machine will cause a light film of oil to accumulate on the underside of the Top Plate where the pneumatic motor exhausts. Make certain your machine is DISCONNECTED from the AIR SUPPLY when filling the Air System Lubricator. Cycle the machine via the foot switch several times to remove air from the system.

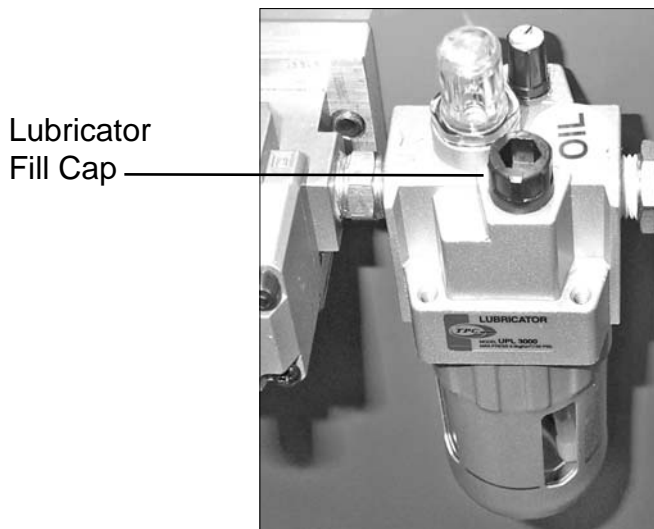







**Kreg Tool Company, 201 Campus Drive, Huxley, IA 50124**  
**800.447.8638 • [www.kregtool.com](http://www.kregtool.com)**